

I-T Characteristics / 時間-電流特性

Ampere Rating 額定電流	% of Ampere Rating 額定電流%	Opening Time 熔斷時間
100mA~6.3A	150%	1 Hrs Min. / 最短1小時
	210%	2Min Max. / 最長2分鐘
	275%	400ms Min. 10s Max. / 最短400毫秒, 最長10秒
	400%	150ms Min. 3s Max. / 最短150毫秒, 最長3秒
	1000%	20ms Min. 150s Max. / 最短20毫秒, 最長150毫秒

In accordance with IEC60127-3 standard, sheet4 / 遵循 IEC60127-3, 規格單4

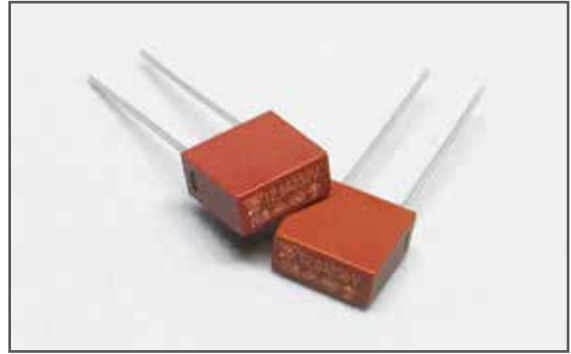

Product Features / 產品特性

Materials 材質	Body / 本體: thermoplastic / 耐熱性塑料 UL94 V-0 Lead / 引線: tinned copper wire / 鍍錫銅線
Operating Temperature 操作溫度	-55°C to +125°C (consider de-rating / 需考慮溫度折減)
Solderability 可焊性	260°C, ≤ 3s. (wave / 波峰焊) 350±10°C, ≤ 3s. (soldering iron / 烙鐵焊)
Resistance to Soldering Heat 耐焊接熱	260°C, 10s. (wave / 波峰焊) 350°C, 3s. (soldering iron / 烙鐵焊)
Recommended Soldering Parameters 建議焊錫參數	Wave soldering parameter / 波峰焊 Soldering pot temperature / 錫爐溫度: 260°C Max Solder dwell time / 焊接時間: 2~5s Hand welding parameter / 手工焊 Soldering iron temperature / 烙鐵溫度: 350±5°C Solder dwell time / 焊接時間: 1~2s Max.
Storage Conditions 儲存條件	Can be stored for 3 years under tight seal condition at temperature of +10°C~60°C, relative humidity ≤ 75%. 在溫度+10°C~60°C, 相對濕度 ≤ 75% 的密閉條件下可存放 3 年。 At most can be kept 30 days at temperature +10°C~60°C, relative humidity ≤ 95% under covered conditions. 在溫度+10°C~60°C, 相對濕度為 95% 的非露天最多可存放 30 天。

Dimensions / 尺寸圖 (Unit / 單位:mm)

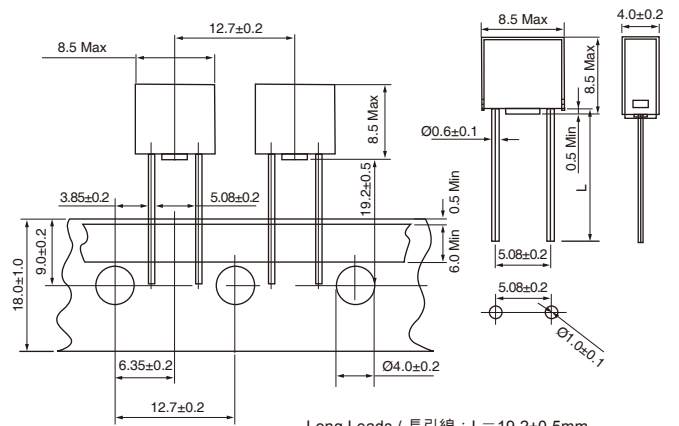

Long Leads / 長引線: L = 19.2±0.5mm
Short Leads / 短引線: L = 4.5±0.5mm

Electrical Characteristics / 電氣特性

Rated Current 額定電流	Rated Voltage 額定電壓	Breaking Capacity 分斷能力	Safety Approvals 安全認證						
			UL US	VDE	TUV	S	CCC	CEC	PS JET
100mA	250V/300V	100A@250V AC & 130A@250V AC	●	●	●	●	●	●	●
125mA	250V/300V		●	●	●	●	●	●	●
160mA	250V/300V		●	●	●	●	●	●	●
200mA	250V/300V		●	●	●	●	●	●	●
250mA	250V/300V		●	●	●	●	●	●	●
315mA	250V/300V		●	●	●	●	●	●	●
400mA	250V/300V		●	●	●	●	●	●	●
500mA	250V/300V		●	●	●	●	●	●	●
630mA	250V/300V		●	●	●	●	●	●	●
800mA	250V/300V		●	●	●	●	●	●	●
1.00A	250V/300V	50A@300V AC & 100A@300V AC	●	●	●	●	●	●	●
1.25A	250V/300V		●	●	●	●	●	●	●
1.60A	250V/300V		●	●	●	●	●	●	●
2.00A	250V/300V		●	●	●	●	●	●	●
2.50A	250V/300V		●	●	●	●	●	●	●
3.15A	250V/300V		●	●	●	●	●	●	●
4.00A	250V/300V		●	●	●	●	●	●	●
5.00A	250V/300V		●	●	●	●	●	●	●
6.30A	250V/300V		●	●	●	●	●	●	●
8.00A	250V/300V		●	●	●	●	●	●	●
10.0A	250V/300V	●	●	●	●	●	●	●	

Remark: For VDE, UL US, CCC, S, 130A at 250V AC and 100A at 250V AC ;

For VDE, UL US, CCC, 50A at 300V AC

For PS JET, 100A at 300V AC